

Work Pro Series

Dual Heated Hot Laminator
(Optional Single Sided/Warm Lamination)

- Hybrid laminating and cutting (Optional)
- Paper shaft for anti-glue purpose
- Available in double-sided or single-sided application
- Premium silicon rollers ensures heavy-duty work and longer life

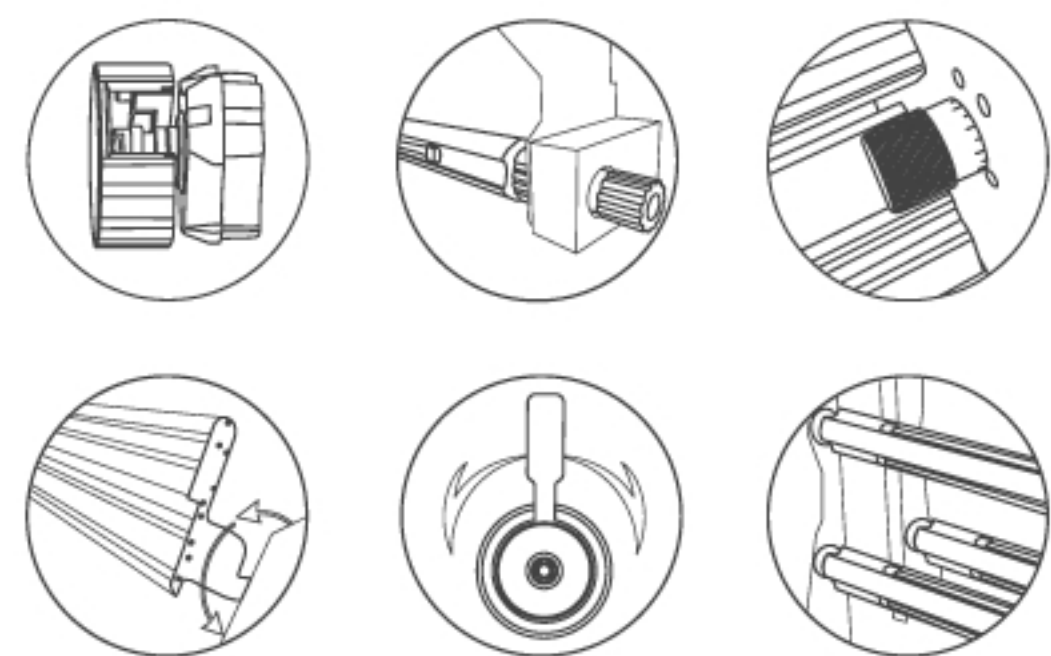

Performance

- Available in double-sided or single-sided application
- Hybrid for both laminating and cutting
- Premium silicon roller ensures heavy-duty work and longer life
- Activate or deactivate cutters by pneumatic bar
- Unique anti-tilt and anti-fold system ensures clear output

Ease of use

- Roller lift by pneumatic
- Simple shafts tension regulation system
- Light weight drop-in supply shafts with auto-grip for easy loading
- Roll-to-Roll application without bubbles and wrinkles

Safety

- Laser safety eyes and 2 emergency stops
- CE, PSE

Parameter

	Work Pro 160	Work Pro 220
Max lamination width	1630mm/64"	2280mm/90"
Max lamination thickness	28mm/1.1"	28mm/1.1"
Max speed	18m/min	18m/min
Max temp	120° C/242° F	120° C/242 F
Up and down	Pneumatic	Pneumatic
Heating	Infrared	Infrared
Warm up time	10-15 min	10-15 min
Power consumption	0.9-1.8 kw/h	0.9-1.8 kw/h
Power input	2600w/5200w	2600w/5200w
Volt	110/220v	110/220v
N.W	260kg	380kg



Diagram

